

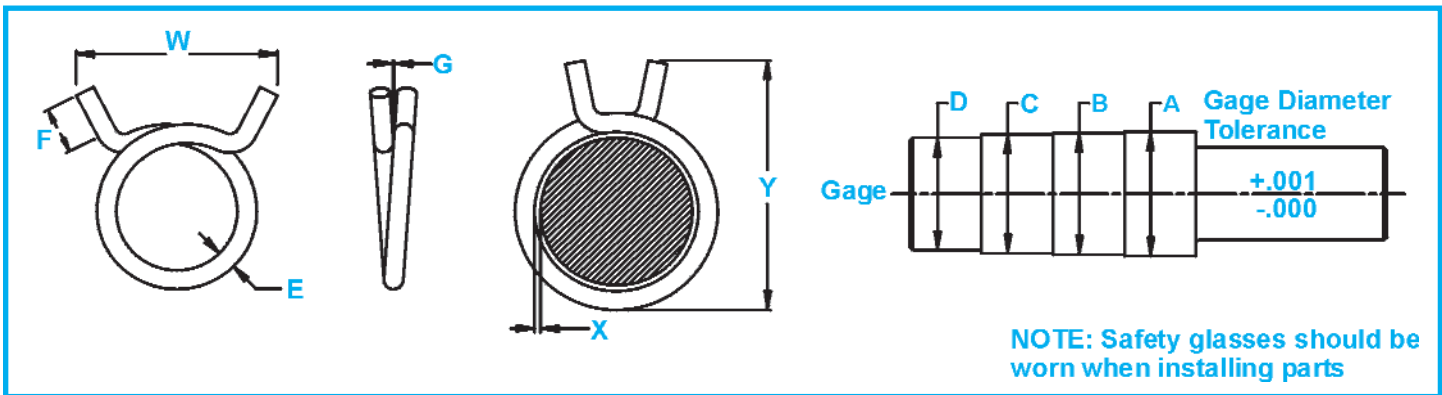

HC Hose Clamps - single Wire



NOTE: Safety glasses should be worn when installing parts

EFFECTIVE CLAMPING RANGE: After expanding to no greater than "A" diameter of the gage, the clamp in relaxed condition shall not pass over "D" diameter. When clamp is assembled on "A", "B" or "C" diameter of gage, a wire of "X" diameter shall not pass between gage and clamp when inserted in a direction parallel to the axis of the gage.

FINISH: Peen-Plate Zinc (non-electrolytic process) .0002 minimum thickness plus dichromate treatment.

MATERIAL: Specially processed premium grade spring wire, hardened and austempered to meet the performance requirements specified.

Note: All Dimensions are in Inches. Conforms to SAE spec. J1508.

Rotor Clamp HC No.	Case Quantity	Approx. Case Weight (lbs.)	EFFECTIVE CLAMPING RANGE				E Nom. Wire Dia.	F Length of Tangs	G Clearance at overlap Max.	W Width over Tangs Max.	X Gaging Wire Max.	Y Overall Height (Ref. Only)	Color Code *	Pneumatic Installation Tool			
			A Max. Dia.	B Nom. Dia.	C Min. Dia.	D No-Go Gage Dia.											
19N	HC-4	15000	25.7	.253	.250	.247	.233	.062	3/8	+.000 -1/32	.010	.75	.003	.88	G	PWS-4	
	HC-5	10000	18.6	.315	.312	.309	.286	.062	3/8		.010	.75	.003	1.00	R	PWS-5	
	HC-5.5	10000	19.8	.345	.342	.339	.320	.062	3/8		.010	.75	.003	1.00	G	PWS-5.5	
35N	HC-6	10000	37.9	.380	.375	.370	.350	.082	3/8	+.000 -1/32	.015	.88	.004	1.06	D	PWS-6	
	HC-7	8000	38.9	.442	.437	.432	.405	.087	3/8		.015	.94	.004	1.12	G	PWS-7	
	HC-7.5	7500	37.5	.473	.468	.463	.430	.087	3/8		.015	1.00	.005	1.12	D	PWS-7.5	
	HC-8	6000	33.7	.510	.500	.490	.462	.092	3/8		.025	1.00	.005	1.19	R	PWS-8	
	HC-8.5	6000	34.8	.541	.531	.521	.492	.092	3/8		.025	1.00	.005	1.38	G	PWS-8.5	
	HC-9	4500	38.0	.573	.562	.551	.520	.107	3/8		.025	1.06	.006	1.38	D	PWS-9	
	HC-9.5	4500	39.0	.604	.593	.582	.550	.107	3/8		.025	1.06	.006	1.38	R	PWS-9.5	
	HC-10	4000	34.8	.640	.625	.610	.580	.107	3/8		.025	1.06	.006	1.38	G	PWS-10	
	HC-10.5	4000	37.6	.671	.656	.641	.611	.107	3/8		.025	1.06	.006	1.38	D	PWS-10.5	
	HC-11	3500	37.0	.703	.687	.671	.635	.112	3/8		.025	1.12	.006	1.50	R	PWS-11	
	HC-12	3000	33.0	.770	.750	.730	.690	.112	3/8		.031	1.19	.008	1.50	D	PWS-12	
	HC-13	2500	30.7	.832	.812	.792	.740	.117	3/8		.031	1.25	.008	1.50	G	PWS-13	
	HC-14	2000	28.2	.900	.875	.850	.800	.122	3/8		.031	1.25	.008	1.62	R	PWS-14	
	HC-15	2000	31.0	.968	.937	.906	.855	.122	3/8		.062	1.25	.008	1.69	D	PWS-15	
	HC-16	1750	32.9	1.031	1.000	.969	.915	.132	3/8		.062	1.31	.008	1.75	G	PWS-16	
HC-17	1400	32.6	1.090	1.062	1.034	.960	.142	3/8	.062	1.50	.010	1.88	R	PWS-17			
HC-17.5	1250	32.5	1.124	1.093	1.065	.991	.152	3/8	.062	1.50	.010	1.90	R	PWS-17.5			
HC-18	1000	28.0	1.150	1.125	1.100	1.030	.152	3/8	.062	1.62	.010	2.00	D	PWS-18			
HC-18.8	1500	26.4	1.150	1.125	1.100	1.030	.122	3/8	.062	1.62	.010	2.00	D	PWS-18.8			
HC-19	1000	28.3	1.218	1.187	1.156	1.095	.152	3/8	.062	1.62	.010	2.00	G	PWS-19			
HC-19.5	1000	29.3	1.250	1.218	1.187	1.126	.152	3/8	±1/32	.062	1.63	.010	2.00	R	PWS-19.5		
HC-20	1000	30.0	1.280	1.250	1.219	1.145	.152	3/8		.062	1.75	.010	2.00	R	PWS-20		
HC-21	800	28.8	1.344	1.312	1.281	1.210	.162	3/8		.062	1.75	.010	2.31	D	PWS-21		
HC-22	800	29.6	1.406	1.375	1.344	1.250	.162	3/8	±1/32	.062	1.88	.010	2.31	G	PWS-22		
HC-23	750	25.5	1.468	1.437	1.406	1.300	.162	3/8		.062	1.88	.010	2.31	R	PWS-23		
HC-24	600	23.4	1.531	1.500	1.469	1.350	.162	3/8		.062	1.88	.010	2.38	D	PWS-24		
1/2 Keg	HC-25	600	23.6	1.592	1.561	1.530	1.411	.162	3/8	+.000 -1/16	.062	1.88	.010	2.53	D	PWS-25	
	HC-26	600	28.8	1.672	1.625	1.578	1.455	.172	3/8		.062	2.00	.010	2.69	D	PWS-26	
	HC-28	500	25.0	1.797	1.750	1.703	1.550	.172	3/8		.062	2.12	.010	2.75	D	PWS-28	
	HC-30	500	29.0	1.937	1.875	1.812	1.675	.177	3/8		.093	2.25	.010	2.88	D	PWS-30	
	HC-31	500	29.5	2.000	1.937	1.875	1.720	.177	3/8		.093	2.25	.010	3.00	D	PWS-31	
	HC-32	500	30.0	2.061	2.000	1.939	1.750	.177	3/8		.093	2.31	.010	3.00	D	PWS-32	
	HC-34	500	31.9	2.187	2.125	2.062	1.860	.182	3/8		-.000	.093	2.31	.010	3.19	D	PWS-34
	HC-35	500	34.2	2.250	2.187	2.125	1.925	.182	3/8			.093	2.31	.010	3.25	D	PWS-35
	HC-36	500	34.5	2.312	2.250	2.187	2.000	.182	3/8			.093	2.38	.010	3.25	D	PWS-36
	HC-38	500	39.5	2.437	2.375	2.312	2.100	.192	3/8			.093	2.38	.010	3.44	D	PWS-38
HC-40	500	41.5	2.561	2.500	2.439	2.187	.192	3/8	+.000 -1/16	.093	2.38	.010	3.62	D	PWS-40		
HC-42	400	39.2	2.688	2.625	2.562	2.320	.220	3/8		.093	2.38	.010	3.75	D	PWS-42		
HC-46	400	41.9	2.938	2.875	2.812	2.625	.220	3/8		.093	2.63	.012	3.88	D	PWS-46		
HC-50	400	53.8	3.218	3.125	3.032	2.844	.220	3/8		.125	3.12	.013	4.00	D	PWS-50		

* GREEN, R-RED, D-DICHROMATE(YELLOW), NOTE: SELECTED SIZES AVAILABLE IN STAINLESS STEEL. INQUIRE FOR AVAILABILITY.